

Short Papers

A Periodic Planar Gunn Diode Power Combining Oscillator

A. MORTAZAWI, STUDENT MEMBER, IEEE, AND T. ITOH,
FELLOW, IEEE

Abstract—Several planar periodic power combining oscillators containing two to six Gunn diodes operating in the X-band are designed and fabricated. The maximum power combining efficiency, 126.7 percent, is obtained from the three-diode oscillator. Injection locking is maintained over a large variation of the bias voltage.

I. INTRODUCTION

There has been extensive research in the area of power combining techniques. A summary of the various techniques is given by Chang and Sun [1]. It is very desirable to design a simple planar power combining oscillator convenient for monolithic fabrication. One way to achieve this goal is through distributed oscillators which allow power combining of several negative resistance devices [2], [3]. In this method negative resistance devices are inserted periodically one half wavelength apart in a planar transmission line structure such as parallel-plane waveguide or microstrip line. This makes the use of external resonator circuits unnecessary and the design of a monolithic circuit easier. The results of several distributed power combining Gunn diode oscillators are presented here. In some of the cases power combining efficiencies larger than 100 percent are obtained.

II. DESIGN PRINCIPLES

For an accurate design, the large-signal impedance of the Gunn diode should be determined. In this experiment, packaged Gunn diodes capable of producing about 10 mW when biased at 8 V with an efficiency of about 1.2 percent are used. To measure the large-signal impedance, a single Gunn diode is connected to a 50 Ω microstrip line. The output of this structure is connected through a bias tee to a triple stub tuner (Fig. 1). The maximum power is obtained at about 10.5 GHz by adjusting the triple stub tuner. Then we disconnect the diode and insert a coaxial cable in its place without disturbing the rest of the circuit. The impedance at the far end of the coax is measured; afterward, the plane of the reference is moved to the diode end of the coax. The large-signal impedance of the Gunn diode is the negative of the impedance measured. Using this large-signal impedance measurement and assuming that the equivalent circuit of the packaged diode consists of a negative resistance in parallel with a capacitance, the values of the negative resistance and the shunt capacitance can be determined. Note that this model is valid only near the frequency of interest.

A distributed power combining oscillator is shown in Fig. 2(a). A transmission line with the characteristic admittance Y_0 is

Manuscript received May 8, 1989; revised August 17, 1989. This work was supported by the Joint Services Electronics Program under Contract AFOSR F 49620-89-C-0044, by the Army Research Office under Contract DAAL03-88-K-0005, and by the Texas Advanced Technology Program.

The authors are with the Department of Electrical and Computer Engineering, University of Texas at Austin, Austin, TX 78712-1084.
IEEE Log Number 8931562.

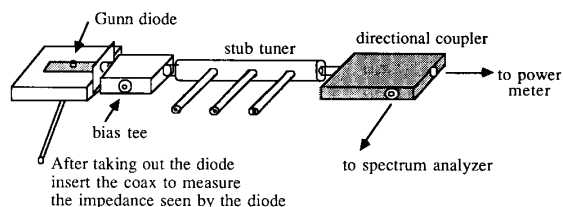

Fig. 1. Measurement of large-signal impedance of the Gunn diode.

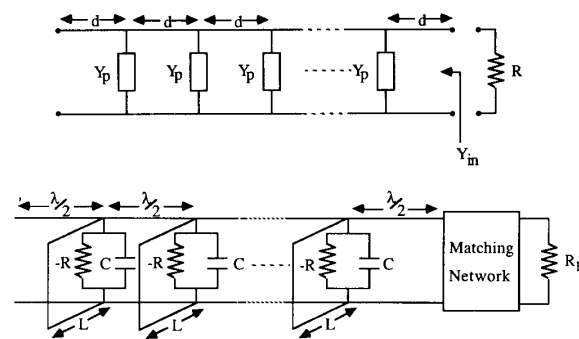

Fig. 2. (a) Transmission line loaded periodically with admittance Y_p . (b) The periodic power combining oscillator. The negative resistance diodes are modeled as a parallel- R/C network. The shorted stubs are to compensate the capacitive part of the device.

loaded periodically with admittances Y_p , each separated by a distance d . The admittance Y_p is the sum of the admittance of the diode and all the parasitics due to discontinuities. Using a simple admittance transformation, we can calculate the admittance Y_{in} as a function of frequency [4]. The frequency at which the imaginary part of Y_{in} goes to zero is the resonance frequency of the structure. To satisfy the oscillation condition the value of the termination resistance R should be equal to $-\text{Real}(Y_{in})$ at the resonance frequency. If Y_p contains only a real part, the periodicity of the structure d will be equal to half a wavelength at the oscillation frequency. Since the diodes are separated by half a wavelength in this case, they are effectively in parallel. Therefore, all of them see the same impedance and operate at the same operating point. To counterbalance the reactive part of the admittances Y_p several inductive stubs can be used (Fig. 2(b)). The shunt inductive stubs compensate the reactive component of the diodes' impedance at the oscillation frequency. Of course a single stub at the end of the structure could also be used to tune out the total capacitance of all the diodes, but in that case the circuit would be very sensitive to the dimensions of the stub.

In any case it can be shown that the impedance each diode sees is the same as the negative of the large-signal impedance we measured (first paragraph) if the periodic structure is terminated properly. For an N -diode oscillator, the proper termination impedance is $1/N$ times the negative of the resistance of the diode. The proper termination impedance can be transformed to

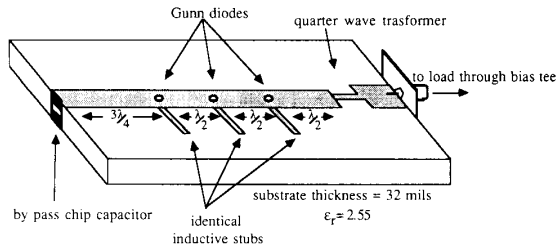

Fig. 3. Three Gunn diode power combining oscillator.

TABLE I
CHARACTERISTICS OF VARIOUS POWER COMBINING OSCILLATORS

N	power (mW)	frequency (GHz)	bias voltage	combining efficiency (%)
1	10.47	10.5	8.5	-----
2	25.0	10.2	8.6	119 %
3	39.8	10.0	8.5	126.7 %
5	63.4	9.5	9.8	121 %
6	56.2	9.9	9.0	89.5 %

N is the number of diodes.

In each case, the bias voltage was adjusted to achieve maximum output power.

50 Ω using a quarter-wave transformer. As the number of diodes increases, the proper termination which satisfies the oscillation condition decreases. Impedance matching between the proper termination and 50 Ω , together with the transmission lines' losses, puts a limit on the number of diodes that can be used in the periodic structure. The maximum number of diodes that can be used to get a high power combining efficiency depends on the type of diode (its large-signal impedance) and the characteristics of the substrate and transmission line. Fig. 3 shows a drawing of the three-diode power combiner.

III. EXPERIMENT

Based on the large-signal impedance of the Gunn diodes, two-, three-, five-, and six-diode power combining oscillators were designed and constructed. After a 10 s warm-up period, the Gunn oscillators injection lock to each other. When phase locking is achieved, the output power can be maximized by fine adjustment of the bias voltage. Injection locking was maintained in spite of large variations in the bias voltage. For example, in the case of the five-diode power combiner, bias voltage variations greater than ± 2 V were required to cause the oscillators to lose phase lock. It should be pointed out that the diodes were not selected to have matched characteristics. Using a power meter, we observed that the output power was maximum if all the Gunn oscillators were injection locked together.

The one-diode planar oscillator produced maximum power of about 10.47 mW at 10.5 GHz with an efficiency of about 1.2 percent. Results obtained from different power combining structures are shown in Table I. The radiation from all the combiners was at least 17 dB below the power absorbed by the load. Except for the six-diode power combiner, combining efficiencies were all more than 100 percent. This is believed to be due to the fact that

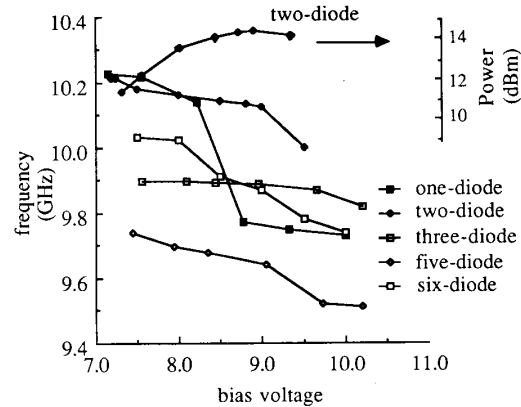

Fig. 4. Variation of the oscillation frequency with bias voltage. Also, the power generated by a two-diode combiner as a function of bias voltage is shown.

better matching to 50 Ω was achieved compared to the single Gunn diode oscillator. The three-diode power combiner had the maximum power combining efficiency. If the proper termination is $1/N$ times the negative resistance, then the matching requirement becomes more severe as the number of diodes is decreased or increased.

The dependence of the oscillation frequency on the bias voltage was investigated. The results are shown in Fig. 4. In general it seems that the dependence of the oscillation frequency on the bias voltage is not a function of the number of diodes in the structure. The bias voltage dependence of power generated by the two-diode combiner is also shown in Fig. 4.

The second harmonic generated by the combiners was also investigated. For the single Gunn diode oscillator, the second harmonic was 21 dB below the fundamental. In the case of two-, three-, five-, and six-diode combiners, the second harmonic was 18.5, 16, 23.3, and 15 dB below the fundamental.

IV. CONCLUSION

Using low-power Gunn diodes, two-, three-, five-, and six-diode distributed power combining oscillators in the X-band were designed and fabricated. The generated powers for the two-, three-, five-, and six-diode combiners were 2.4, 3.8, 6.1 and 5.4 (combining efficiencies of 119, 126.7, 121, and 89.5 percent respectively) times the power produced by a single-diode oscillator, respectively. The frequency dependence of all the power combiners on the bias voltage variation seemed to be independent of the number of diodes. It was observed that when injection locking was achieved it was maintained over relatively large variations of the bias voltage.

REFERENCES

- [1] K. Chang and C. Sun, "Millimeter-wave power-combining techniques," *IEEE Trans. Microwave Theory Tech.*, vol. MTT-31, pp. 91-107, Feb. 1983.
- [2] Y. Fukuoka and T. Itoh, "Millimeter-wave travelling-wave Impatt diode," Microwave Laboratory Rep. 84-7, University of Texas at Austin.
- [3] B. Bayraktaroglu and H. D. Shih, "High-power 60 GHz monolithic GaAs Impatt diodes," *Electron Lett.*, vol. 22, pp. 562-563, May 1986.
- [4] V. P. Kesan, A. Mortazawi, D. P. Neikirk, and T. Itoh, "Monolithic millimeter-wave oscillator using a transmission line periodically loaded by QWITT diodes," *Electron. Lett.*, vol. 24, pp. 666-667, May 1988.